

ELP5 PRO-VCI
INSTRUKCJA OBSŁUGI



DIAGPROG5
INSTRUKCJA OBSŁUGI



SKLEP
ONLINE



*DZIĘKUJEMY ZA TWOJE ZAUFANIE
I ZAKUP URZĄDZENIA DIAGPROG5*

TABLET – FRONT

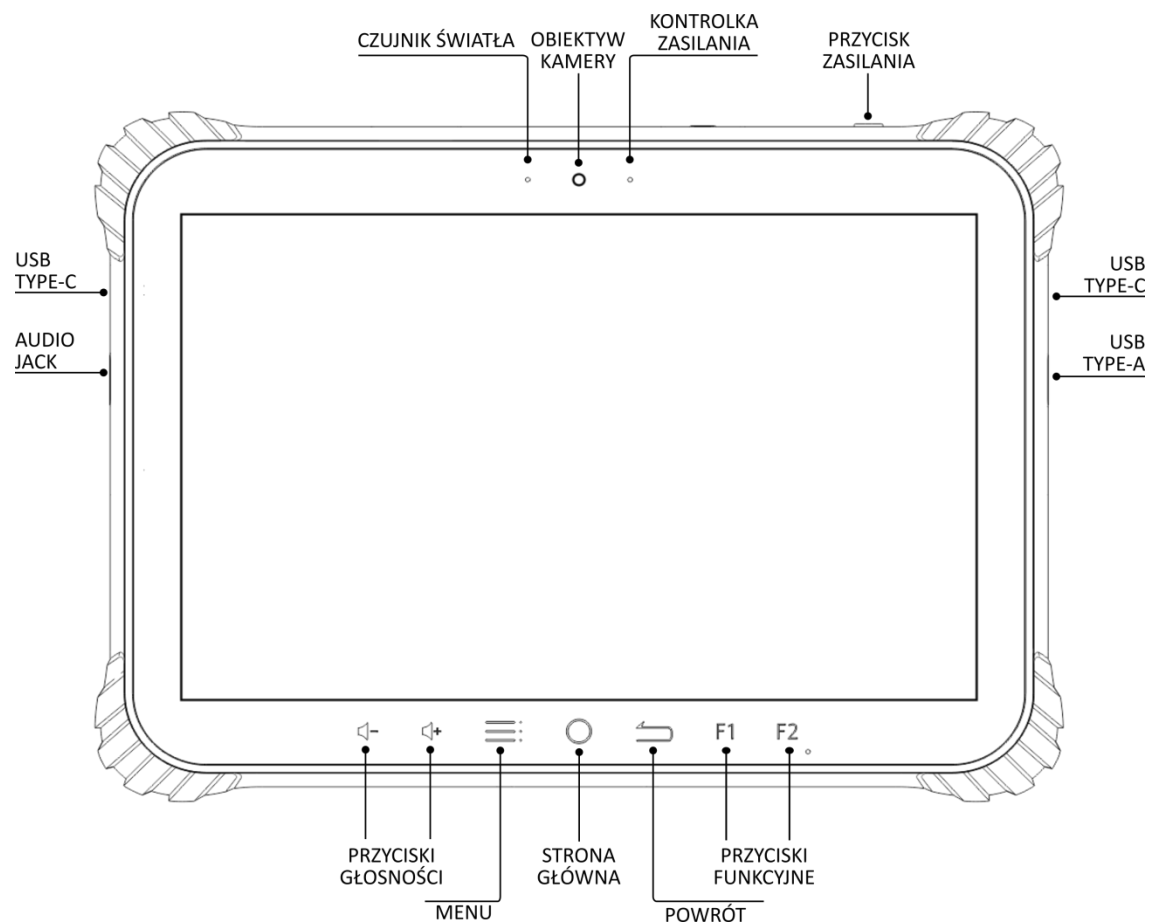

TABLET – REWERS

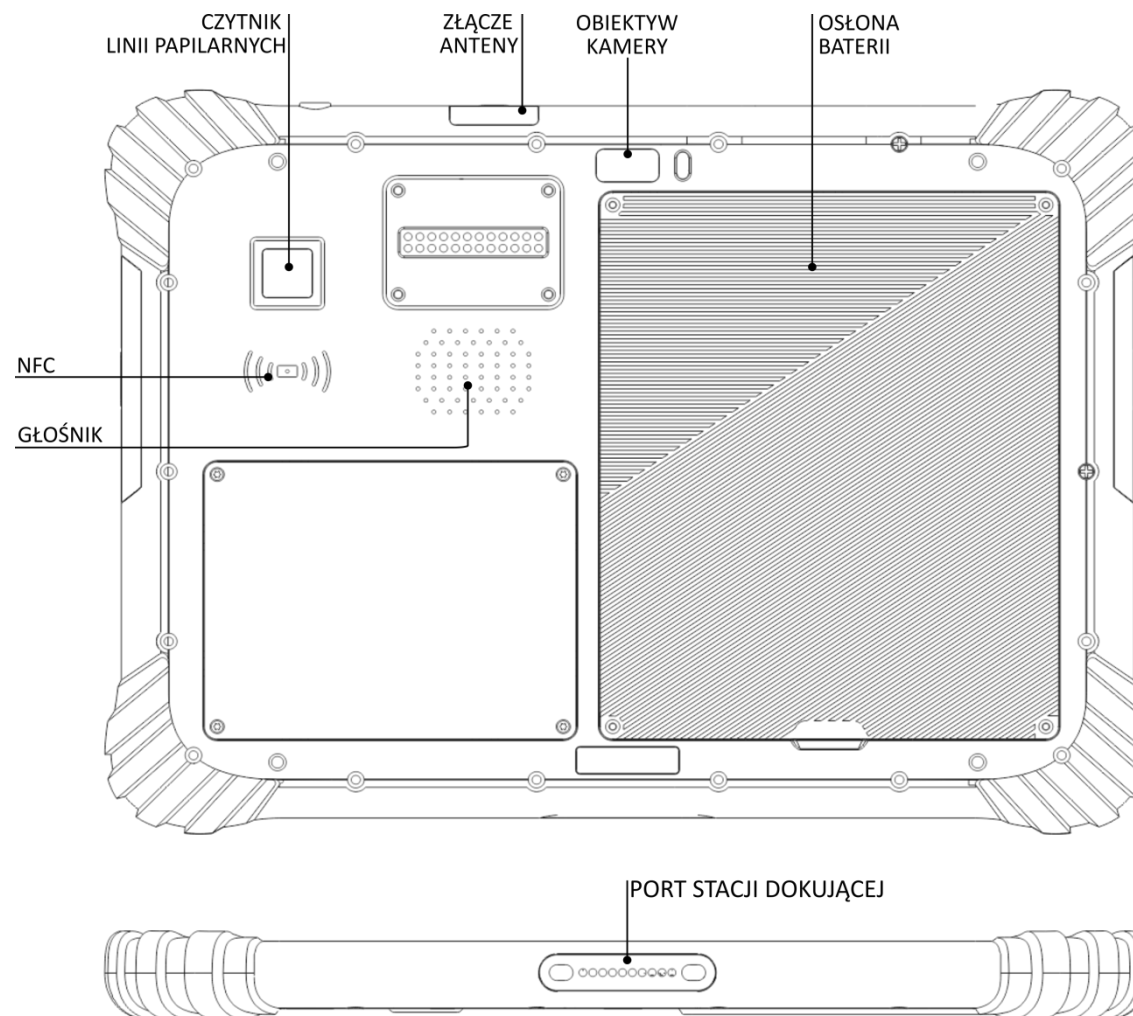

ELP5 PRO – VCI – FRONT

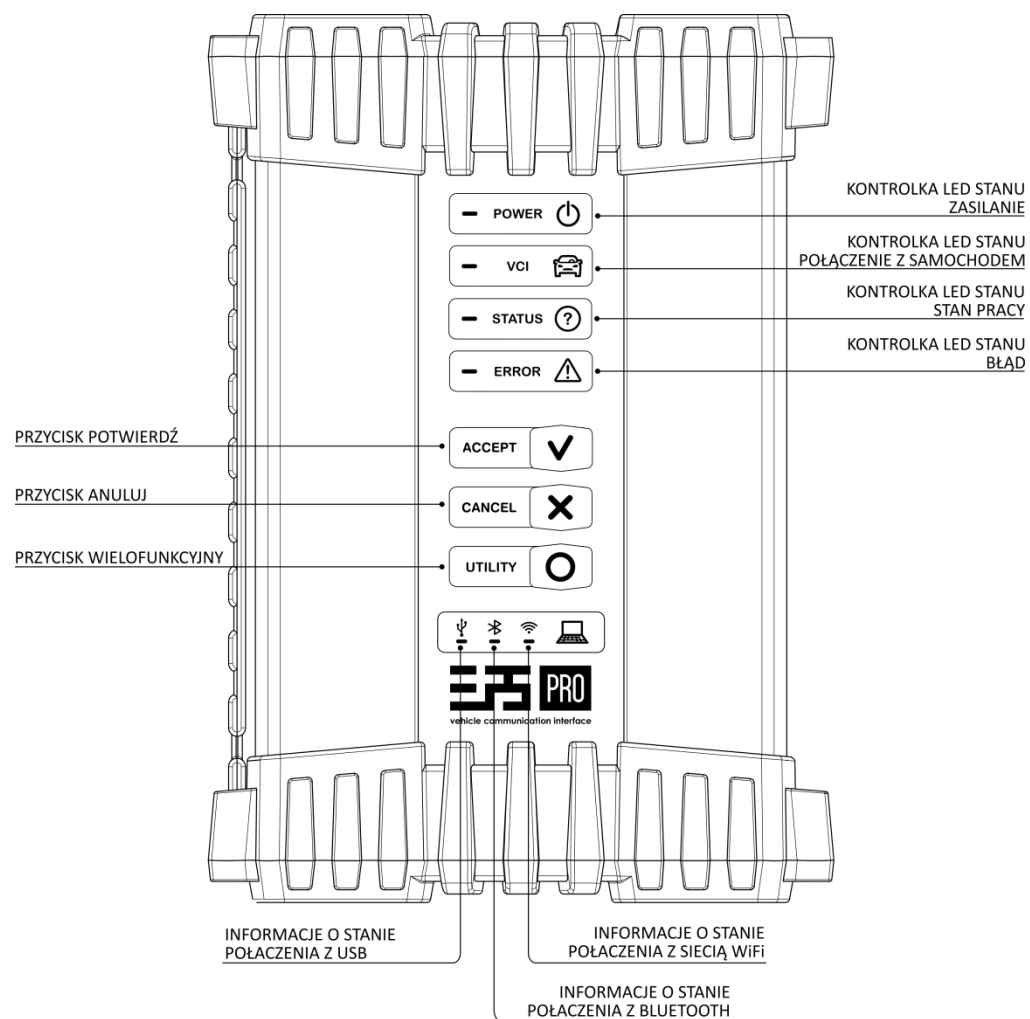

ELP5 PRO – VCI – ZŁĄCZA

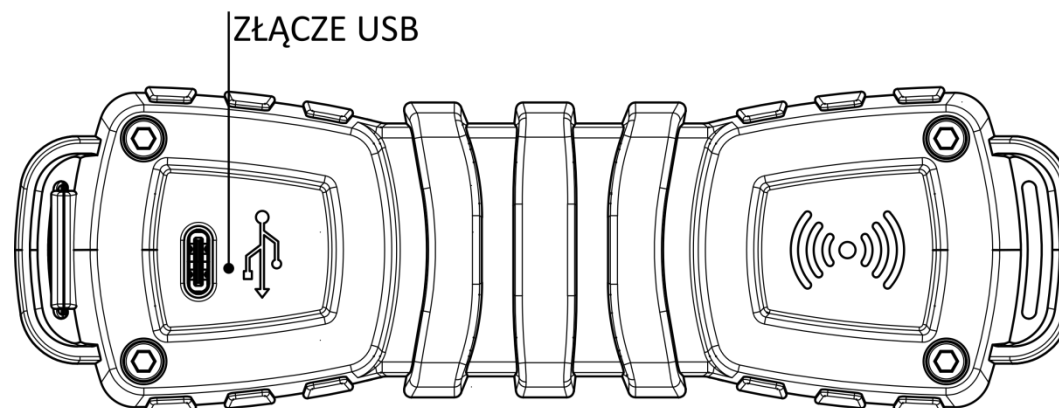
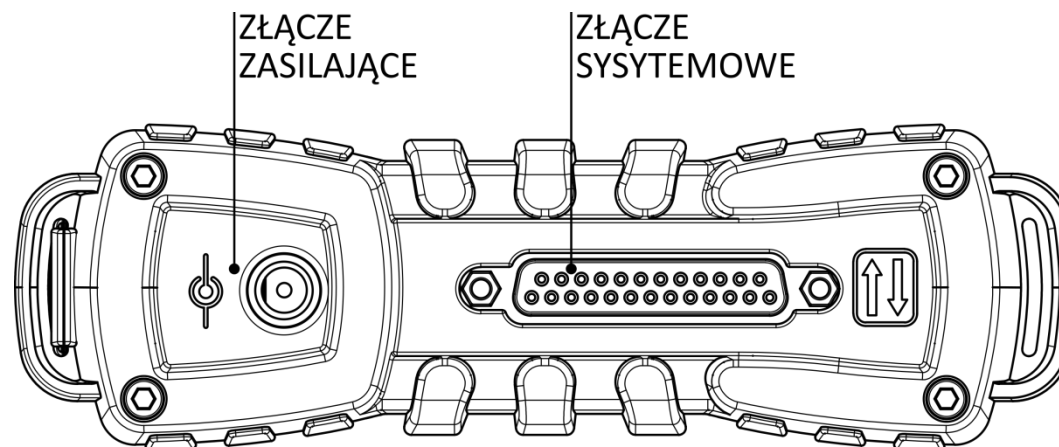

DIAGPROG5 PIERWSZE URUCHOMIENIE

1

Na tablecie wciśnij i przytrzymaj przycisk zasilający.

UWAGA: W przypadku niskiego poziomu stanu baterii podłącz do źródła zasilania.

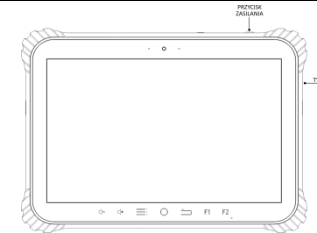

2

Po uruchomieniu systemu pojawi się ekran powitalny. Przejdź przez proces wstępnej konfiguracji obejmujący m.in. wybór języka, ułatwień dostępu.

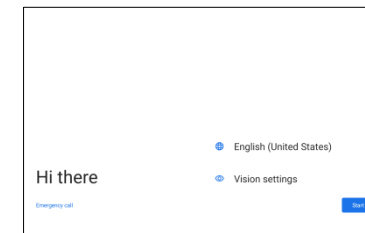

3

Połącz tablet z siecią WiFi:

1. wybierz odpowiedni SSID sieci
2. wprowadź hasło

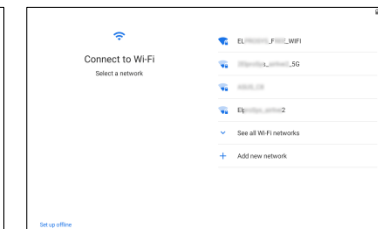
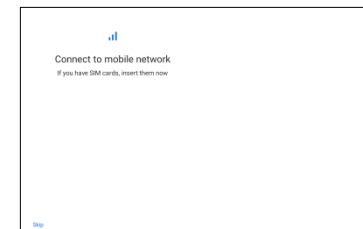

4

Zaloguj się do konta Google lub utwórz nowe konto. Przeczytaj i zaakceptuj warunki usług Google.

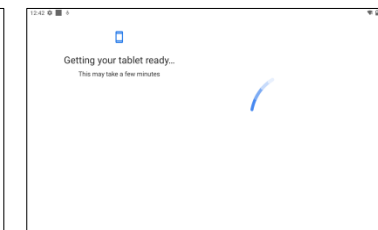
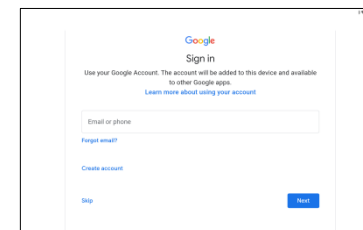

5 Na ekranie startowym kliknij i przytrzymaj ikonę programu DP5.
Wybierz kolejno: informacje o aplikacji -> Szczegóły aplikacji.
W przypadku dostępności, wykonaj aktualizację.



6 Uruchom aplikację DP5 i zaakceptuj warunki umowy.

OPROGRAMOWANIE DIAGPROG5 JEST DEDYKOWANE I DOSTOSOWANE DO PRACY Z TABLETEM DOŁĄCZONYM DO ZESTAWU. ELPROSYS NIE GWARANTUJE POPRAWNEGO DZIAŁANIA APLIKACJI DP5 NA INNYCH URZĄDZENIACH.



7 Połącz VCI do tabletu:

1. Podłącz zasilanie do VCI
2. Wybierz systemowe ustawienia Bluetooth tabletu i wskaż swoją głowicę VCI
3. W aplikacji DP5 kliknij VCI manager
4. Kliknij Połącz poprzez Bluetooth

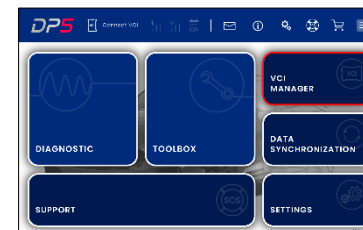
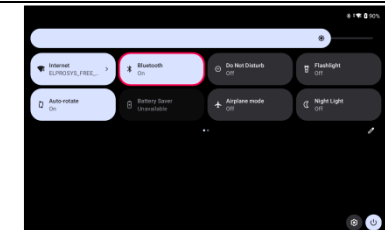
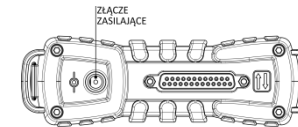

8 Wykonaj update oprogramowania i przeprowadź aktywację pakietu oprogramowania DP5.
Uruchom aplikację DP5 następnie z ekranu głównego wybierz:
VCI MANAGER -> UPDATE VCI FIRMWARE
VCI MANAGER -> DOWNLOAD ACTIVATION

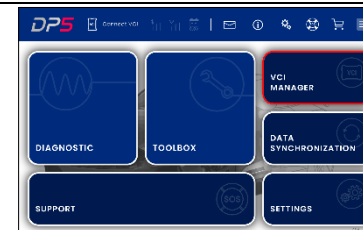

Gratulacje, proces aktywacji został zakończony.

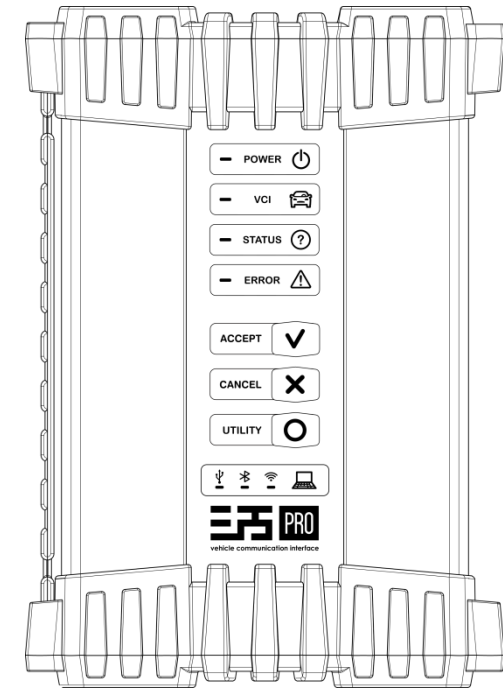

ELP5 PRO-VCI
MANUAL



DIAGPROG5
SOFT MANUAL



ONLINE
SHOP



*THANK YOU FOR YOUR TRUST
AND PURCHASE OF THE DIAGPROG5 DEVICE*

TABLET – FRONT

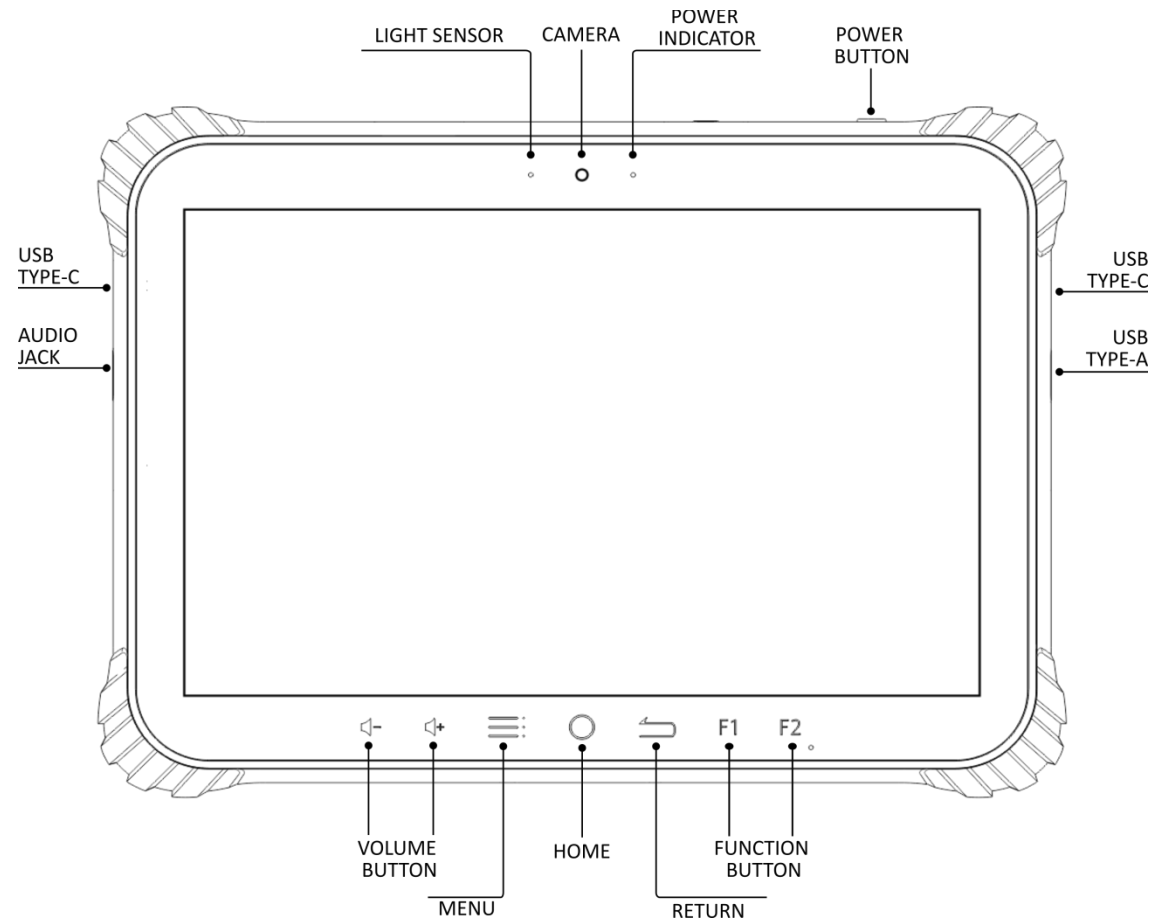

TABLET – REVERSE

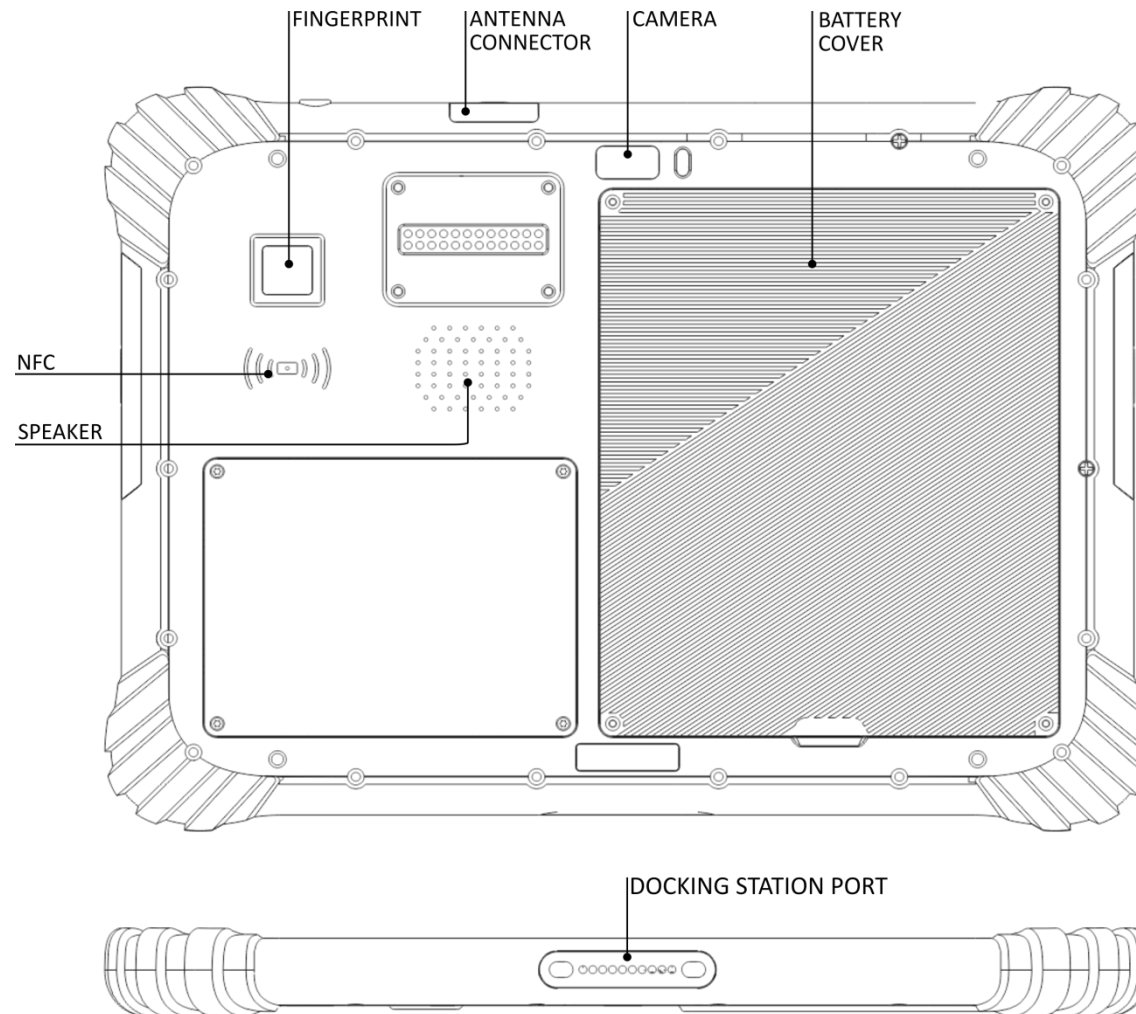

ELP5 PRO – VCI – FRONT

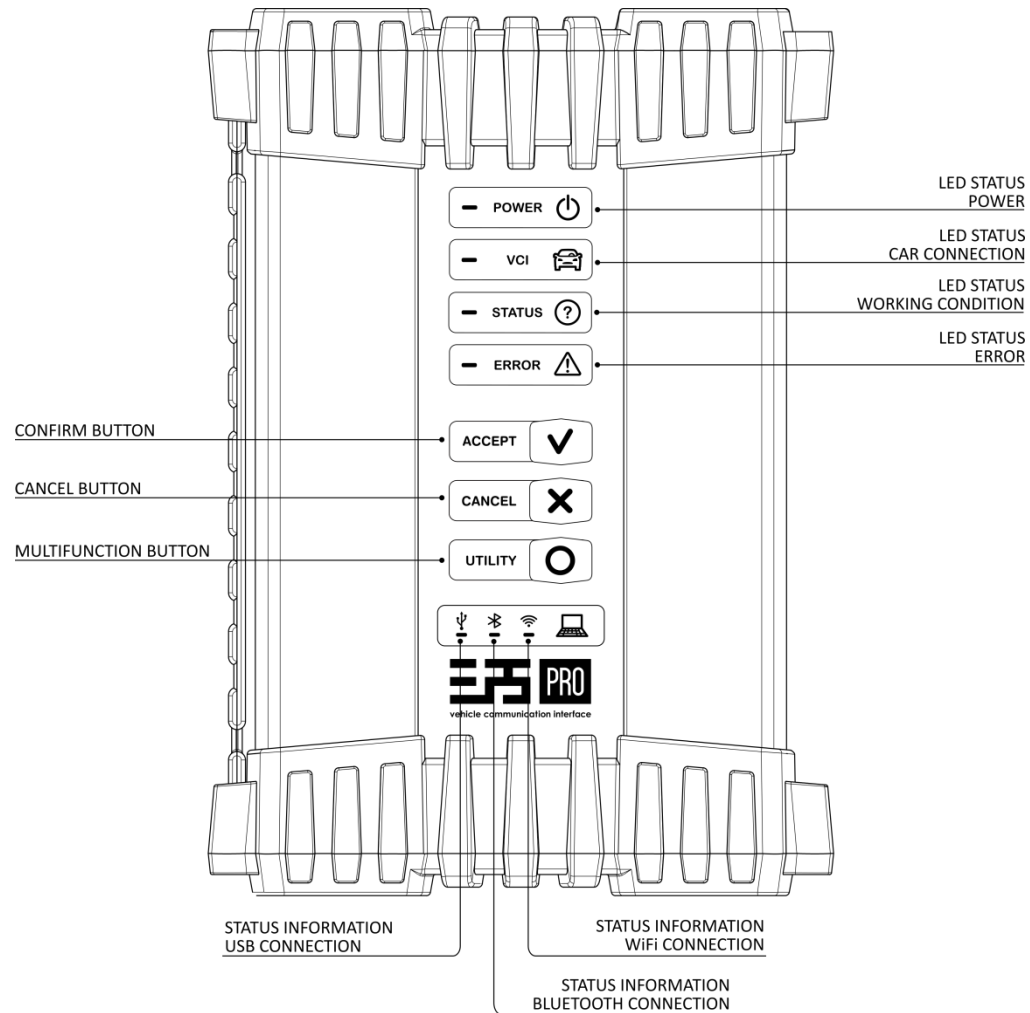

ELP5 PRO – VCI – CONNECTORS

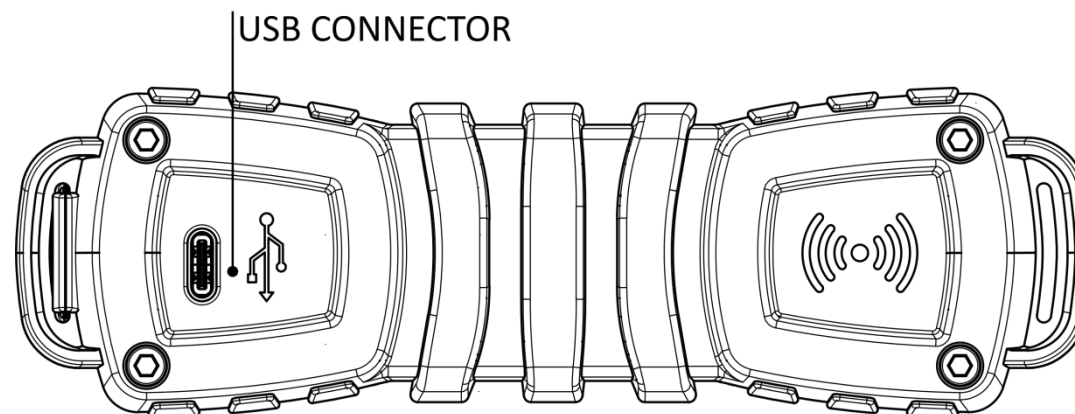
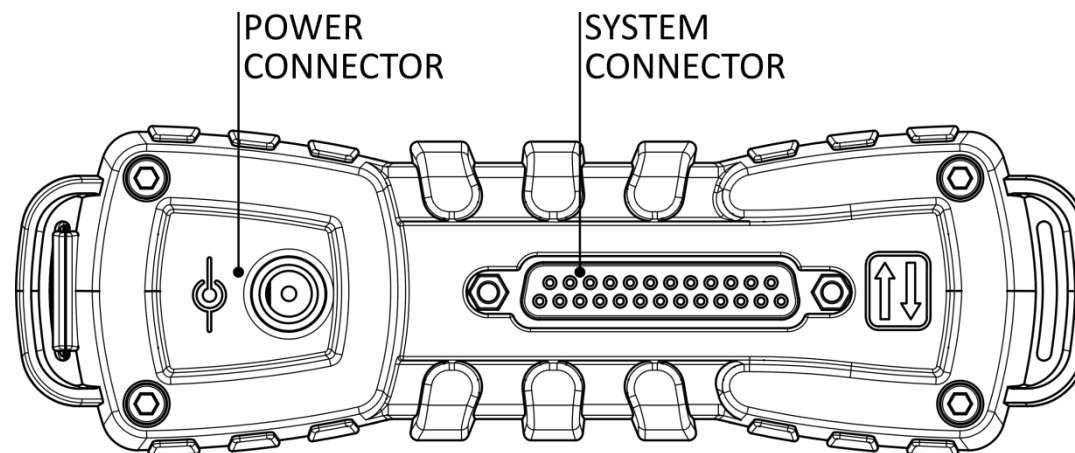

DIAGPROG5 – FIRST START

1 On the tablet, press and hold the power button until the ELPROSYS logo is displayed.

NOTE: In case of the appearance of an empty battery icon, charge the tablet.

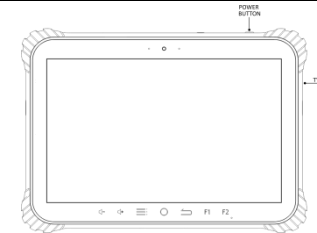

2 After starting the system, the welcome screen will appear. Go through the initial setup process, which includes language selection and accessibility.

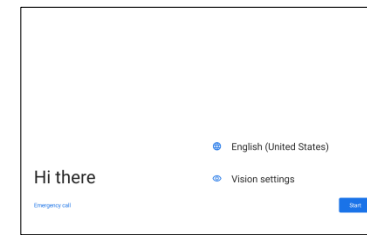

3 Connect your tablet to the WiFi network:
 1. select the appropriate network SSID,
 2. enter your password

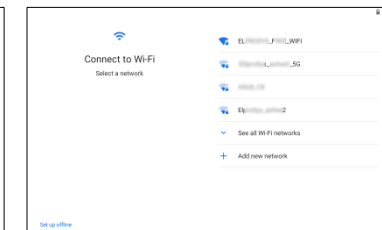
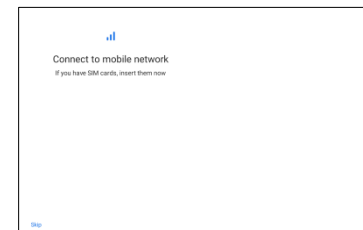

4 Sign in to your Google account, or create a new account. Read and accept the terms of Google services.

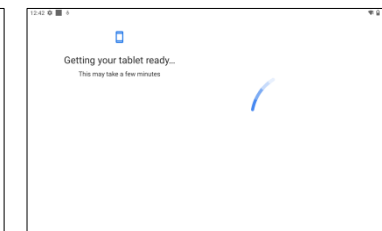
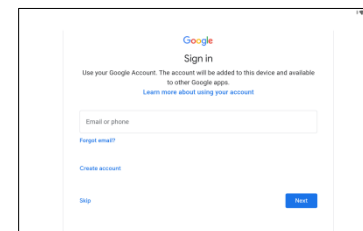

5 From the main screen press and hold the icon of DP5 App.
 Select App Info -> App Details.
 In case of availability of the new version of the App perform the update.



6 Run the DP5 App and accept the terms of the agreement.

**THE DP5 SOFTWARE IS DEDICATED AND PREPARED FOR WORK WITH THE TABLET INCLUDED IN THE SET.
 ELPROSYS DOES NOT GUARANTEE THE PROPER WORK OF THE DP5 APP ON OTHER DEVICES.**



7 Connect VCI to Tablet:

1. Power on VCI
2. From the Bluetooth settings of the tablet select your VCI
3. In DP5 App select VCI Manager
4. Click connect by Bluetooth

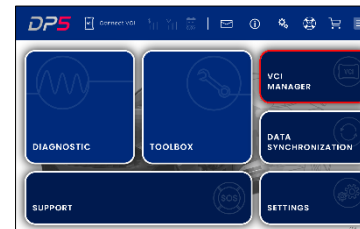
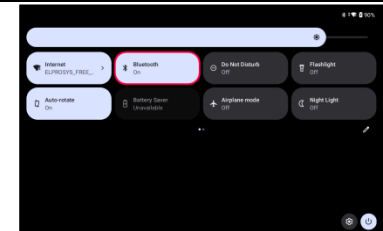
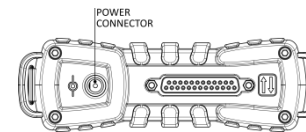

8 Perform the update and activate the DP5 software package.
 Start the DP5 application then from the main screen select:

VCI MANAGER -> UPDATE VCI FIRMWARE
VCI MANAGER -> DOWNLOAD ACTIVATION

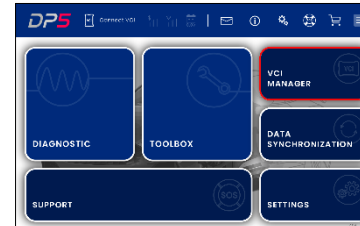

Congratulations, the activation process is complete.